

**LLS48-15**  
SCALE: 3/4"=1'-0"

BILL OF MATERIAL	
QTY	DESCRIPTION
1	CHECKER PLATE, 55 1/2" x 14 15/16" x 1/4"
3	3" x 2 1/2" x 1/4" ANGLE 54 1/2" LENGTH
2	3/16" x 2 1/2" FLAT BAR, 14 7/16" LENGTH
2	3/16" x 2" FLAT BAR, 14 7/16" LENGTH

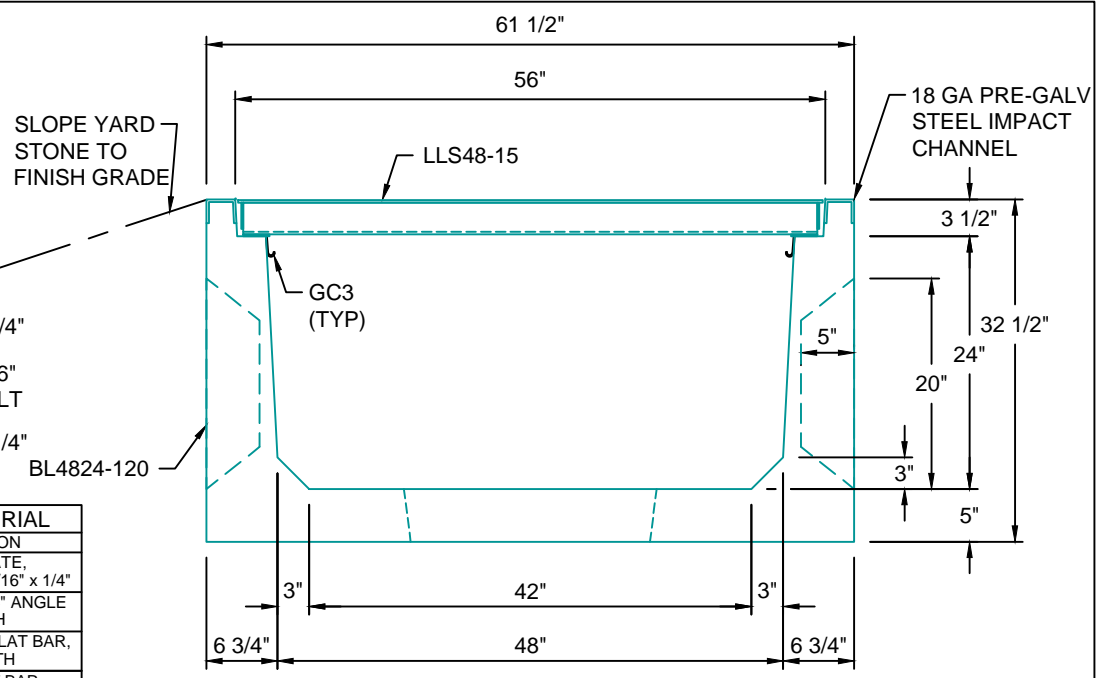

**TYPICAL LIGHT TRAFFIC SECTION WITH STEEL LID 48"W x 24"D**  
SCALE: 1" = 1'-0"

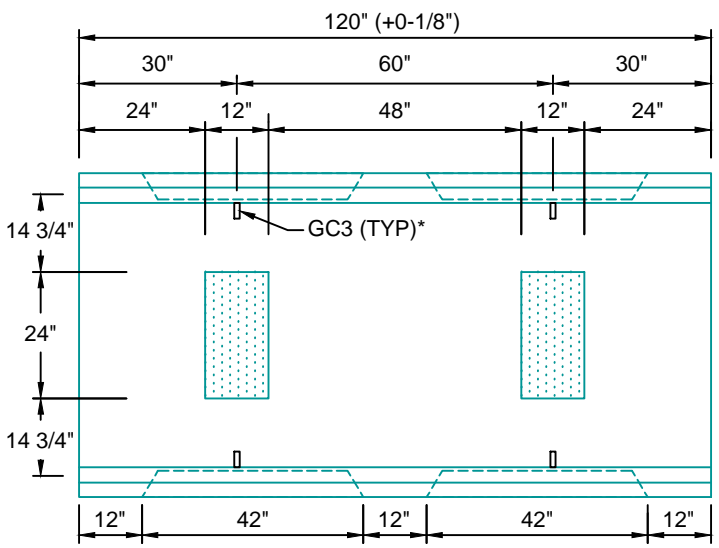

**BL4824-120**  
SCALE: 1/2" = 1'-0"  
WEIGHT: 6120 #

\*GC3 (GROUND CLIPS) OPTIONAL

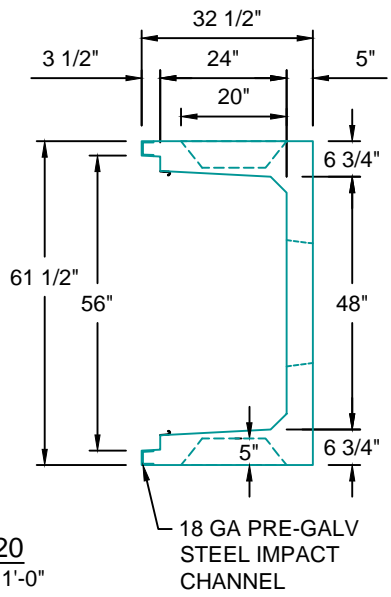

**H10 DESIGN**  
**(16,000 LBS / AXLE)**

<b>Trenwa Inc.</b>		
1419 ALEXANDRIA PIKE FORT THOMAS, KY 41075 859-781-0831		
<b>TYPICAL LIGHT TRAFFIC BASE, STEEL LID &amp; SECTION FOR 48" WIDE x 24" DEEP TRENCH</b>		
Date: 9/25/2017	Dwg. No. BL4824-120	